

FMH220P-FC-SUPER

Owner's Manual

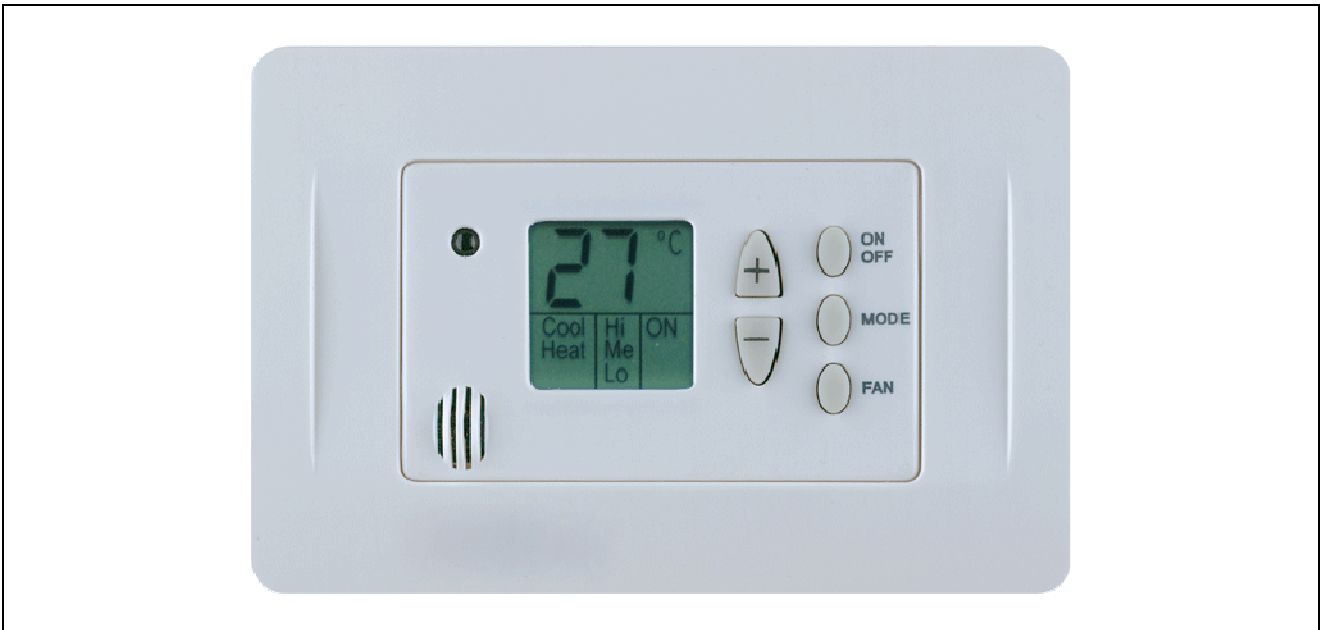

Installation Instructions	1
Wiring Connections	2
DIP Switch Configuration	3
External Sensor Connection	4
Operating Manual	5
IR Remote Control – option	6
Technician Settings	7
Proportional Outputs Settings	8
Remote Switch Connection	9



Meitav-tec Ltd (Contel group)

Tel: +972-3-9626462 Fax: +972-3-9626620

www.meitavtec.com - support@meitavtec.com

1. Installation Instructions

The FMH220P-FC-SUPER thermostat is designed for flush mounting in the room to be controlled. It should be located where the occupant can easily read the LCD display and use the controls. If the built in temperature sensor is being used to measure room temperature, the module should be placed where the temperature is representative of the general room conditions. Cold or warm air draughts; radiant heat and direct sunlight should be avoided.

General points to follow

- Disconnect power to the main board before installing the unit.
- The unit **MUST** be fitted into a standard electrical box (Gewiss Box - GW00001481VR)
- The unit should not be installed on an outside wall or where there is an air draft.
- The unit must not be exposed to a direct sunlight.
- The standard height to install this unit is 1.5 meter (5 feet) from the floor.

Installation procedure

- A. Connect the wires as shown in the enclosed wiring diagram. All terminals on accept $1 \times 0.5 \text{ mm}^2 / 24 \text{ AWG}$.
- B. Place the thermostat in the electrical box and tighten up the 2 screws (Gewiss Box - GW00001481VR).
- C. Adapt the front frame-panel into its place, by pushing it towards the wall.

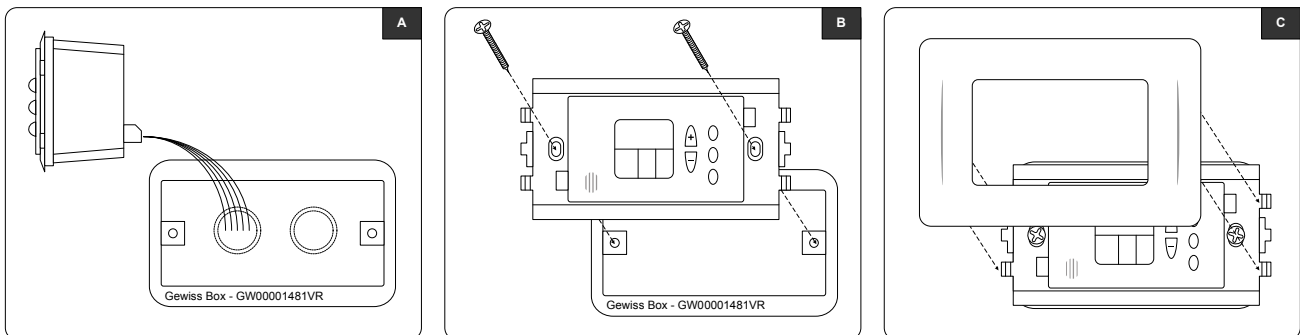

2. Wiring Connections

IMPORTANT! High and Low voltage wires must be separated.

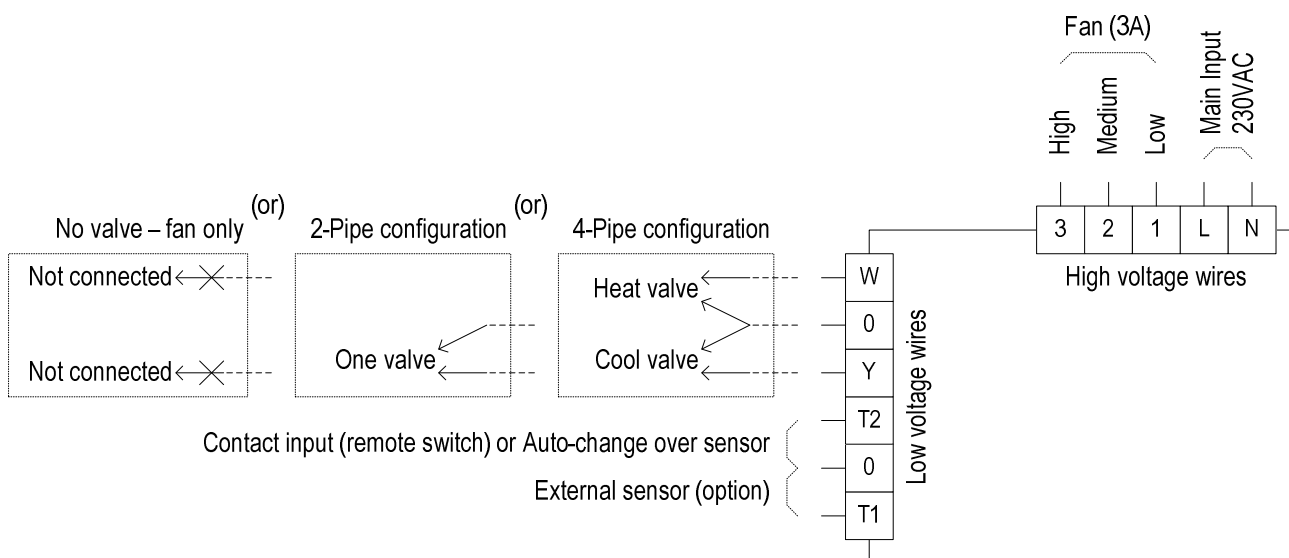

3. DIP Switch Configuration

IMPORTANT! Disconnect power to the thermostat before making any changes.

DIP Switch location and default position

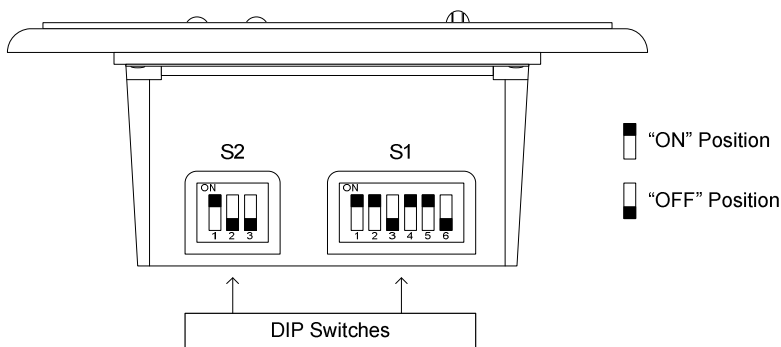

DIP Switches configuration

Switch	“ON” Position	“OFF” Position	Default
S1.1	Auto-Change Over Sensor	Contact Input	ON
S1.2	4-Pipe system	2-Pipe system	ON
S1.3	1 Fan speed	3 Fan speeds	OFF
S1.4	With auto change over mode	Without auto change over mode	ON
S1.5	Set-point and Room temp. display	Set-point temp. display only	ON
S1.6	Always Auto fan	Auto fan selectable	OFF
S2.1	Internal sensor	External sensor	ON
S2.2	External sensor	Internal sensor	OFF
S2.3	External sensor	Internal sensor	OFF

4. External Sensor Connection (option)

Follow these steps to install Meitav-tec's external sensor

- Disconnect power to the thermostat.
- Change DIP switch configuration to external sensor (S2.1=OFF, S2.2=ON, S2.3=ON).
- Connect the temperature sensor to "T1" and "0" terminals.
- Reconnect power.
- Make sure that the reading on display is by the external sensor.

Important! The remote temperature sensor must be Meitav-tec type.

Maximum Length with Shield Cable: The wire length for the remote sensor can be up to 30 meters with standard thermostat cable (not less than 22AWG).

If the distance is greater than 30 meters, the wire MUST be twisted and shielded, 20-22AWG.

The cable must not pass by or be close to any High Voltage Lines or Devices.

At 200 meters, the resistance may affect the temperature readings by one or two degrees.

Different Applications

TS01

Connection of one remote sensor (80 cm cable)

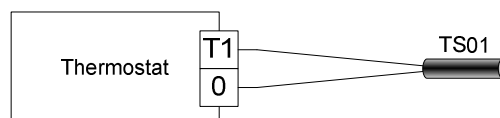

RS01

Connection of one remote sensor (in decorative boxes)

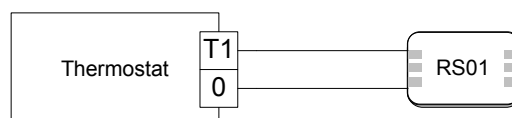

RS02

Connection of two remote sensors (in decorative boxes) for average measuring

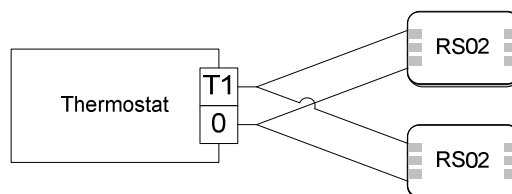

Temperature ~ Resistance Characteristics

Temp °C	7.2	10.0	12.8	15.6	18.3	21.1	23.9	26.7	29.4	32.2
Temp °F	45	50	55	60	65	70	75	80	85	90
Res. K	115.8	100.9	88.1	77.1	67.7	59.6	52.5	46.4	41.2	36.6

5. Operating Manual

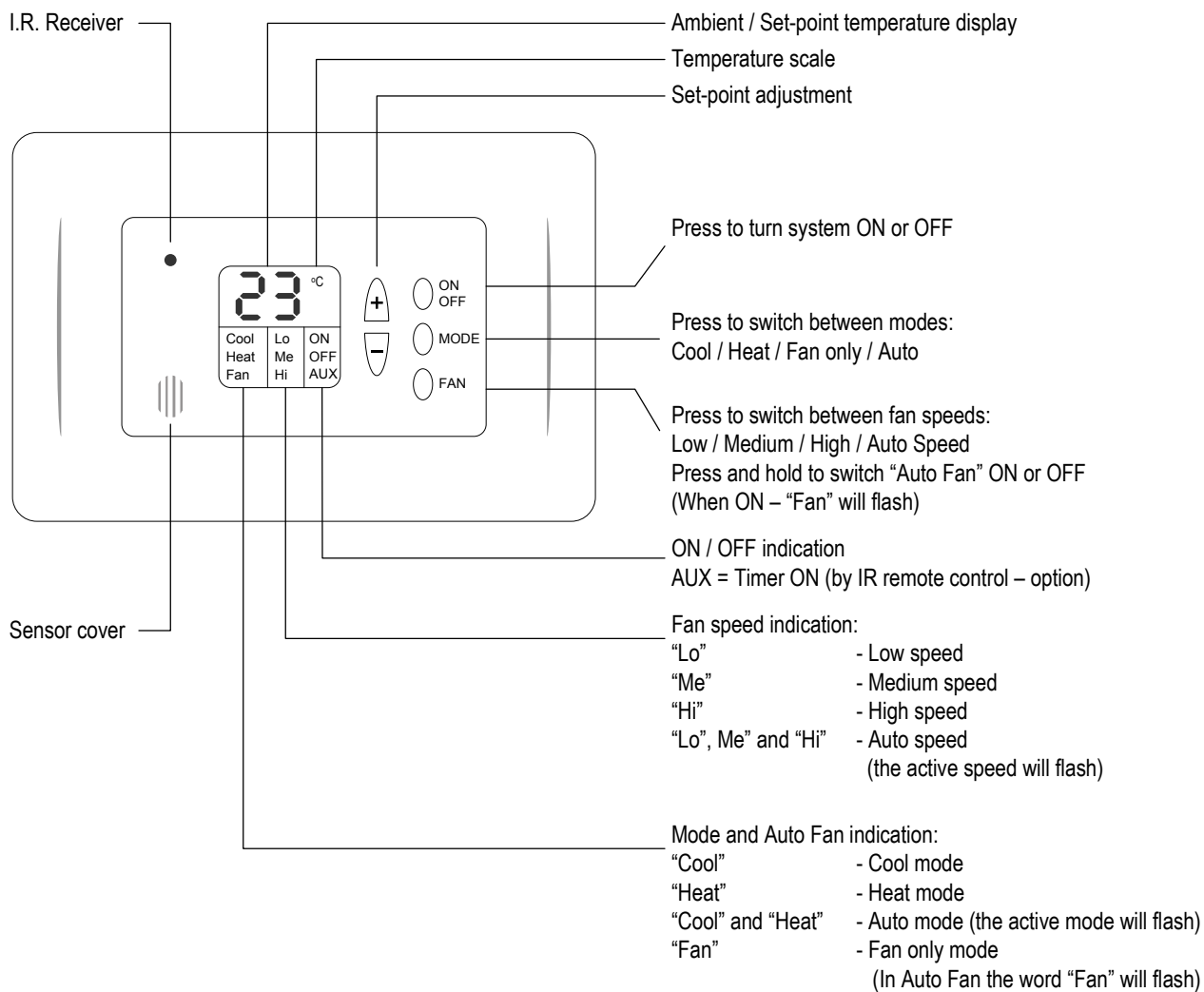

6. I.R. Remote Control (option)

General

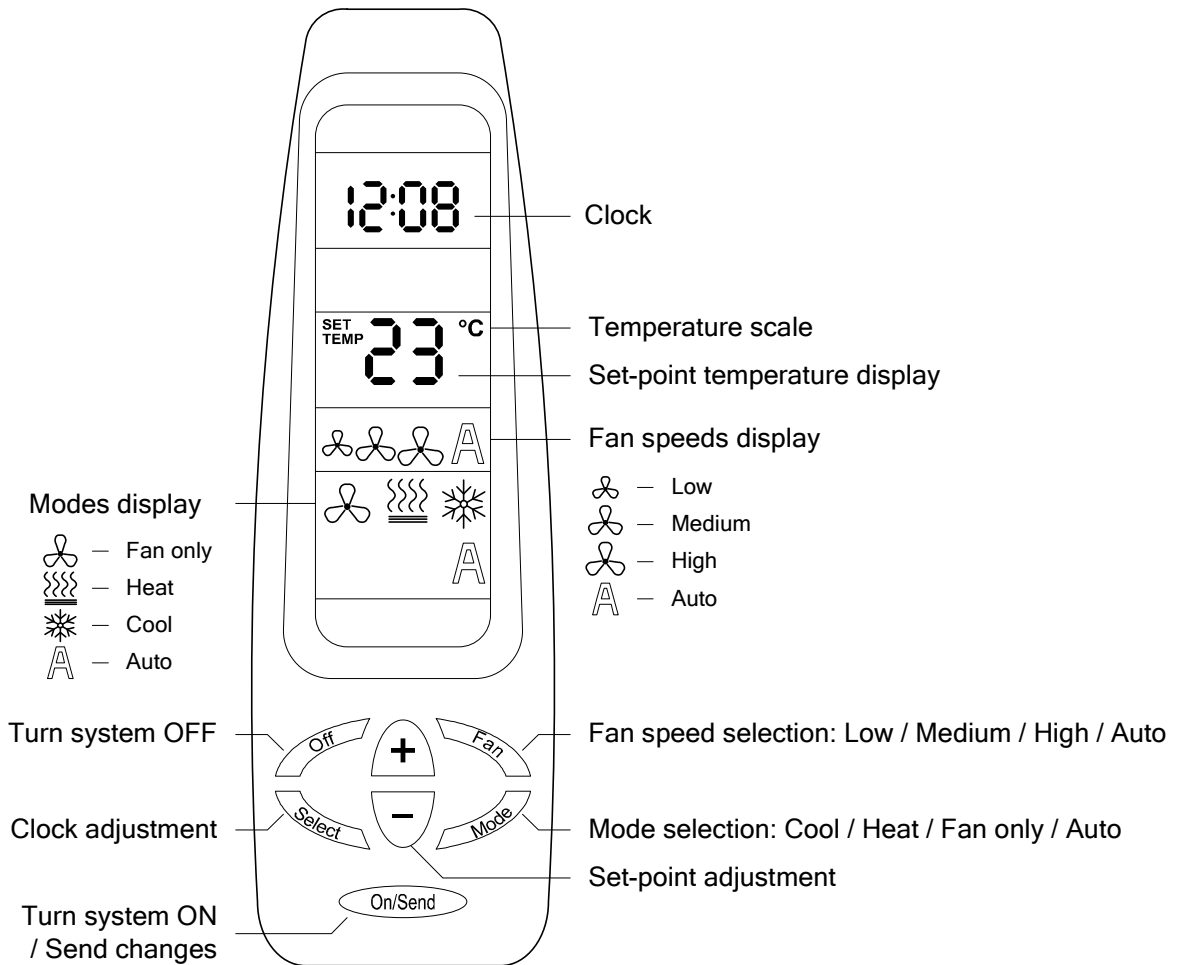

Real Time Clock and Day

- Press the [Select] button - CLOCK SET will flash.
- Press the [+] or [-] buttons - the hours will flash.
- Adjust the hours using the [+] or [-] buttons.
- Press the [Select] button again - minutes will flash.
- Adjust the minutes using the [+] or [-] buttons.
- Press the [Select] button again to return to normal display mode.
- Press the [On/Send] button to send information to the thermostat.



I.R. Remote Control (option) – Cont'

Timer

Start Time

- Press the [Select] button twice - PROGRAM & START (flashing) will appear on display.
- Press the [+] or [-] buttons - the hours will flash.
- Adjust the hours using the [+] or [-] buttons.
- Press the [Select] button - the minutes will flash.
- Adjust the minutes using the [+] or [-] buttons.

Stop Time

- Press the [Select] button - PROGRAM & STOP (flashing) will appear on display.
- Press the [+] or [-] buttons - the hours will flash.
- Adjust the hours using the [+] or [-] buttons.
- Press the [Select] button - the minutes will flash.
- Adjust the minutes using the [+] or [-] buttons.
- Press the [Select] button - the TIMER will blink
- Select TIMER ON () or TIMER OFF () Using the [+] or [-] buttons.
- Press the [On/Send] button to send the information to the thermostat.
- Press the [Select] button to return to normal display mode.

Note: When the TIMER is used, "AUX" will appear on the thermostat's display.

Batteries Replacement

When the batteries are low, the display of the remote control will dim.

If the batteries will not be replaced the display will turn off completely.

- Pull the batteries cover down to reveal the batteries.
- Remove the old batteries.
- Wait for 10 minutes before installing the new batteries.
- Install two new AAA batteries – Pay attention to the polarity.
- Return the batteries cover to place.

Important: The remote control will not operate unless at least 10 minutes pass between removing the old batteries and installing the new ones.

7. Technician Settings

Technician can have access to the following features:

- High temperature limit (HEAT)
- Low temperature limit (COOL)
- Lock buttons
- Offset for calibration of measured temperature
- Auto change over sensor or Remote switch selection
- Economy mode set-points
- Beeper ON or OFF

Enter technician settings

- Adjust the set-point temperature to 10°C.
- Press and hold the [MODE] button (7 sec.) until the display flashes.

Low and High temperature limits

- Using the [+] or [-] buttons adjust the High temperature limit (HEAT)
(Range 10-30°C, default 30°C).
- Press the [MODE] button again.
- Using the [+] or [-] buttons adjust the Low temperature limit (COOL)
(Range 10-30°C, default 10°C).

Lock the buttons

- Press the [Mode] button again and choose the state of security:
 - OP** = OPEN (enable all buttons).
 - LC** = Lock the [MODE] and [FAN] buttons.

Offset

- Press the [MODE] button again – a digit between –6 and +6 will appear on display.
- Using the [+] or [-] buttons adjust the OFFSET for temperature reading.

Auto change over sensor / Remote switch

- Press the [MODE] button again and choose between activating or deactivating the Input (T2-0)
 - Option for Auto-Change Over Sensor or Remote Switch.

bF = Input (T2-0) is **not active**- thermostat works normally.

bO = **Auto-Change Over sensor logic** (available for 2-pipe system only)
or **Contact Input logic**.

When “bO” is selected - follow the steps below to configure the output application:

Auto-Change Over Sensor (Cool/Heat Logic)

When Auto-Change Over sensor is selected, the system mode (Cool/Heat) is automatically selected according to the temperature. In that case, the [MODE] button is not active.

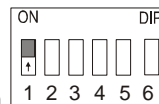

- Move DIP switch S1.1 to “**ON**” position
- Press the [MODE] button and select the “**EF**” option.

Contact input (remote switch)

The Contact Input can be set to work in three different modes:

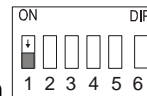

- Move DIP switch S1.1 to “**OFF**” position
- Press the [MODE] button and select one of the following options:

EF = Mode selection (via the remote switch)

Change the system mode through one remote switch, attached to one or more thermostats. It is suitable for hotel rooms and offices, when the system mode cannot be defined differently for each thermostat.

- Remote switch close - HEAT
- Remote switch open – COOL

E1 = Turn system On/Off (via the remote switch)

- Remote switch close – Thermostat work normally (On or Off selected by user).
- Remote switch open – Turn thermostat OFF.

E2 = Activate Economy mode (via the remote switch)

- Remote switch close – Thermostat work normally.
- Remote switch open – Thermostat works according to economy set-points and fan speed always low.
 - Thermostat in cool mode → economy set-point for cooling
 - Thermostat in heat mode → economy set-point for heating

Economy set-points

- Press the [MODE] button again – “AUX” and “Cool” will appear on display.
- Using the [+] or [-] buttons adjust the temperature set-point for cooling in economy mode (Range 10-30°C, default 30°C).
- Press the [MODE] button again – “AUX” and “Heat” will appear on display.
- Using the [+] or [-] buttons adjust the temperature set-point for heating in economy mode (Range 10-30°C, default 10°C).

Beeper On / Off

- Press the [MODE] button again – “AUX” and “BO” or “BF” will appear on display.
- Using the [+] or [-] buttons select between:
 - BF** = Beeper OFF
 - BO** = Beeper ON
- Press the [MODE] button again or wait 20 seconds to return to normal display.

8. Proportional Outputs Settings

Technician can have access to the following features:

- Low and High limits for the Proportional Heat and Cool outputs.
- Proportional band for Heat and Cool.
- Dead zone for Heat and Cool.

Enter technician settings

- Adjust the set-point temperature to 11°C.
- Press and hold the [MODE] button (7 sec.) until “Heat” and “Lo” appear on display.

Low and High limits for the Heat and Cool Proportional outputs

Note: “0” = 0%, “00” = 100%

- Using the [+] or [-] buttons adjust the Low limit (%) for the Heat proportional output (Range 0-100%, default 0%).
- Press the [MODE] button again – “Heat” and “Hi” will appear on display.
- Using the [+] or [-] buttons adjust the High limit (%) for the Heat proportional output (Range 0-100%, default 100%).
- Press the [MODE] button again – “Cool” and “Lo” will appear on display.
- Using the [+] or [-] buttons adjust the Low limit (%) for the Cool proportional output (Range 0-100%, default 0%).
- Press the [MODE] button again – “Cool” and “Hi” will appear on display.
- Using the [+] or [-] buttons adjust the High limit (%) for the Cool proportional output (Range 0-100%, default 100%).

Proportional band for Heat and Cool

- Press the [MODE] button again – “Heat” and “Aux” will appear on display.
- Using the [+] or [-] buttons adjust the proportional band for Heat (Range 2-10°C, default 2°C).
- Press the [MODE] button again – “Cool” and “Aux” will appear on display.
- Using the [+] or [-] buttons adjust the proportional band for Cool (Range 2-10°C, default 2°C).

Dead Zone for Heat and Cool

- Press the [MODE] button again – “Heat” and “Cool” will appear on display (“Heat” will flash).
- Using the [+] or [-] buttons adjust the Dead Zone for Heat
(Range 0-5°C, default 1°C).
- Press the [MODE] button again – “Heat” and “Cool” will appear on display (“Cool” will flash).
- Using the [+] or [-] buttons adjust the Dead Zone for Cool
(Range 0-5°C, default 1°C).

- Press the [Mode] button again or wait 20 seconds to return to normal display.

9. Remote Switch Connection

Installation of remote switch

- Connect the “T2” and the “0” terminals of the thermostats as shown in the illustration below.
- Connect the “T2” and “0” terminals of the last thermostat to the remote switch.

